

# Introduction of Gamma-ray Spectrometer

Date : 22 July 2016 ( Friday )

Venue : Seminar Room, G/F, Block A,  
Queen Elizabeth Hospital, Kowloon

Time : 6:45 pm – 7:45 pm

---

Title : Introduction of Gamma-ray Spectrometer

Speaker : Ron Mak,  
MEng CEng MIET MHKIE  
Ficom Systems Ltd

## Topic :

- What is gamma-ray spectroscopy
- Components of gamma-ray spectrometer
- Commonly Used Gamma-ray Detectors
- Performance Comparison among different detector types
- Formats of gamma-ray spectrometer
- Applications of gamma-ray spectrometers
- Q & A Session

# Gamma-ray Spectroscopy (1) :

Gamma spectroscopy is the science of [identification](#) and [quantification](#) of radionuclides by analysis of the gamma-ray energy spectrum produced in a [gamma-ray spectrometer](#) for more than 50 years.

That is to produce the [Nuclides Composition](#) & their respected [Activities](#).

A [gamma-ray spectrometer](#) is an instrument for measuring the distribution ( [spectrum](#) ) of the intensity of gamma radiation versus energy of each [photon](#).

Because the energy of each photon of EM radiation is proportional to its frequency, gamma rays have sufficient energy that they are typically observed by counting individual photons.

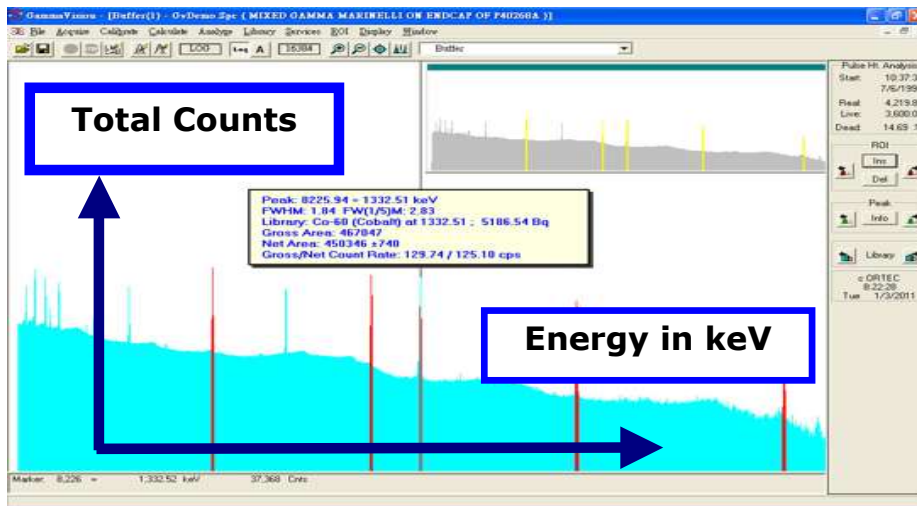
# What is gamma spectrometer (2) :

It is an electronic instrument which :

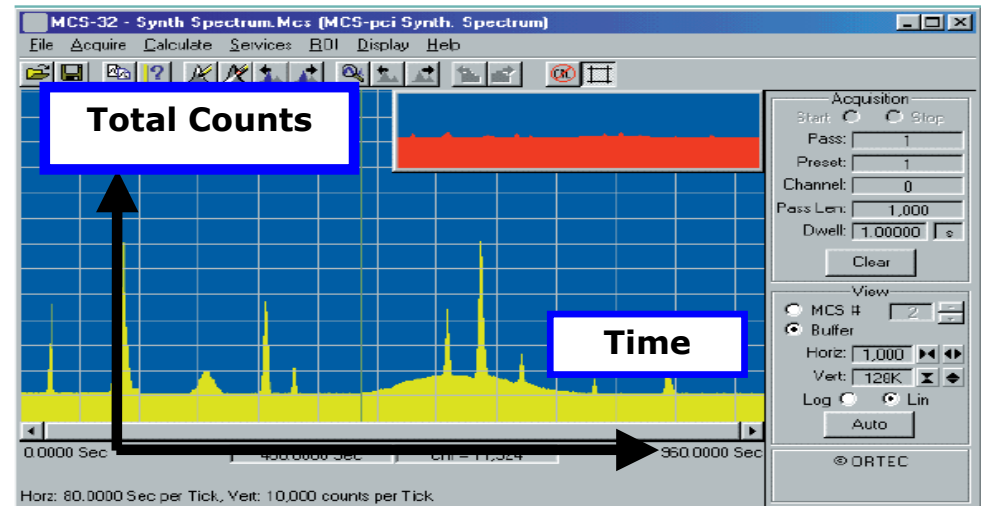
- Detects gamma-ray ( photon ) radiations & produce electrical pulses
- Pulses are then **sorted** to form spectrum for analysis :

a. Energy Spectrometer ( Multi-Channel Analyzer / **MCA** ) :  
**Total Counts** of each photon energy over a period of time

b. Time Spectrometer ( Multi-Channel Scaler / **MCS** ) :  
**Total Counts** per unit ( dwell ) time from reference time



Energy Spectrum



Time Spectrum

## Typical Applications :

<b>Multi-Channel Analyzer ( MCA )</b>	<b>Multi-Channel Scaler ( MCS )</b>
Environmental Radioactivity Monitoring	Time-resolved single-photon counting
Health Physics Personnel Monitoring	Phosphorescence lifetime spectrometry
Materials Testing Reactor Corrosion Monitoring	Atmospheric and satellite LIDAR
Materials Testing	Laser-induced chemical reactions
Forensics and Nuclear Forensics	Scanning mass spectrometers
Nuclear Medicine and Radio-pharmaceuticals	Time-of-flight spectrometry
Geology and Mineralogy	Scanning X-ray diffractometers
Nuclear Materials Safeguards and Homeland Security	Mössbauer experiments

# Components of Gamma-ray Spectroscopy System and their functions (1) :

## (1) Detector & Preamplifier :

- detects gamma radiations
- signal conditioning

## (2) Detector bias power supply :

- provide electric field to collect detector charges

## (3) Low-background shielding :

- suppress background influence to sample
- contain radiations from sample

## (4) Detector cooling system :

- semiconductor detectors such as High-Purity Germanium (HPGe), CdTe and old type CZT ( Cadmium Zinc-Telluride ) require to cool to operating temperature due to thermal noise at room temp.

## Components of Gamma-ray Spectroscopy System and their functions (2) :

(5) Electronics of spectroscopy amplifier, digital filters, power supply

- signal processing of detector signals

(6) Multi-Channel Analyzer / Buffer ( MCA / MCB )  
( Analog-to-Digital Converter )

- digitized amplified signal and transfer to computer
- ADC ranges from 1, 2, 4, 8, 16 and 32k channels

***[ Note : system resolution is dominant by detector resolution ]***

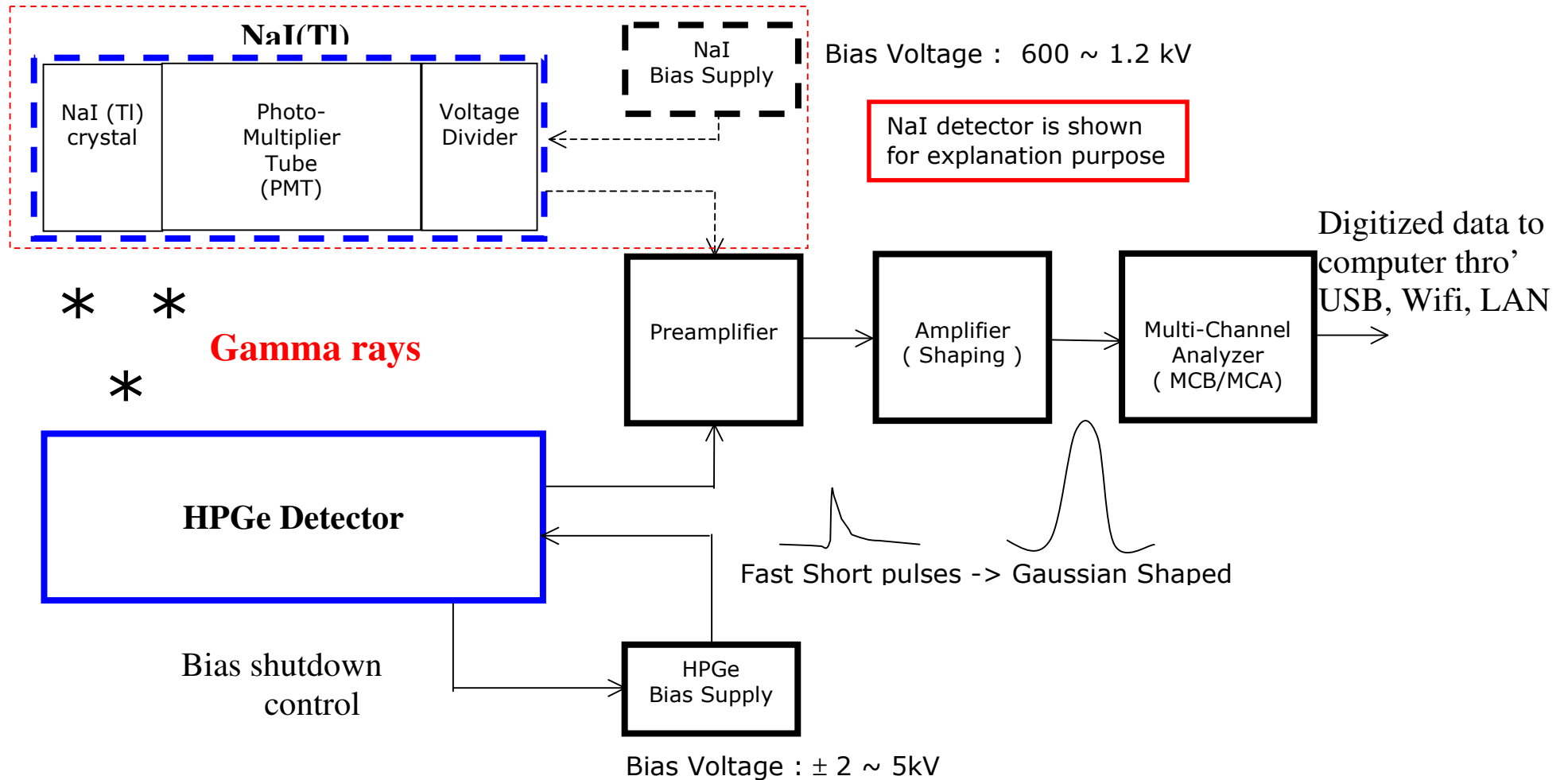
(7) Control and analysis software

- configure MCA according to applications
- control MCA for data acquisition and spectrum analysis

(8) Calibration Standards and Software

- derive calibration curves for measurement samples

# System Connection Diagram :

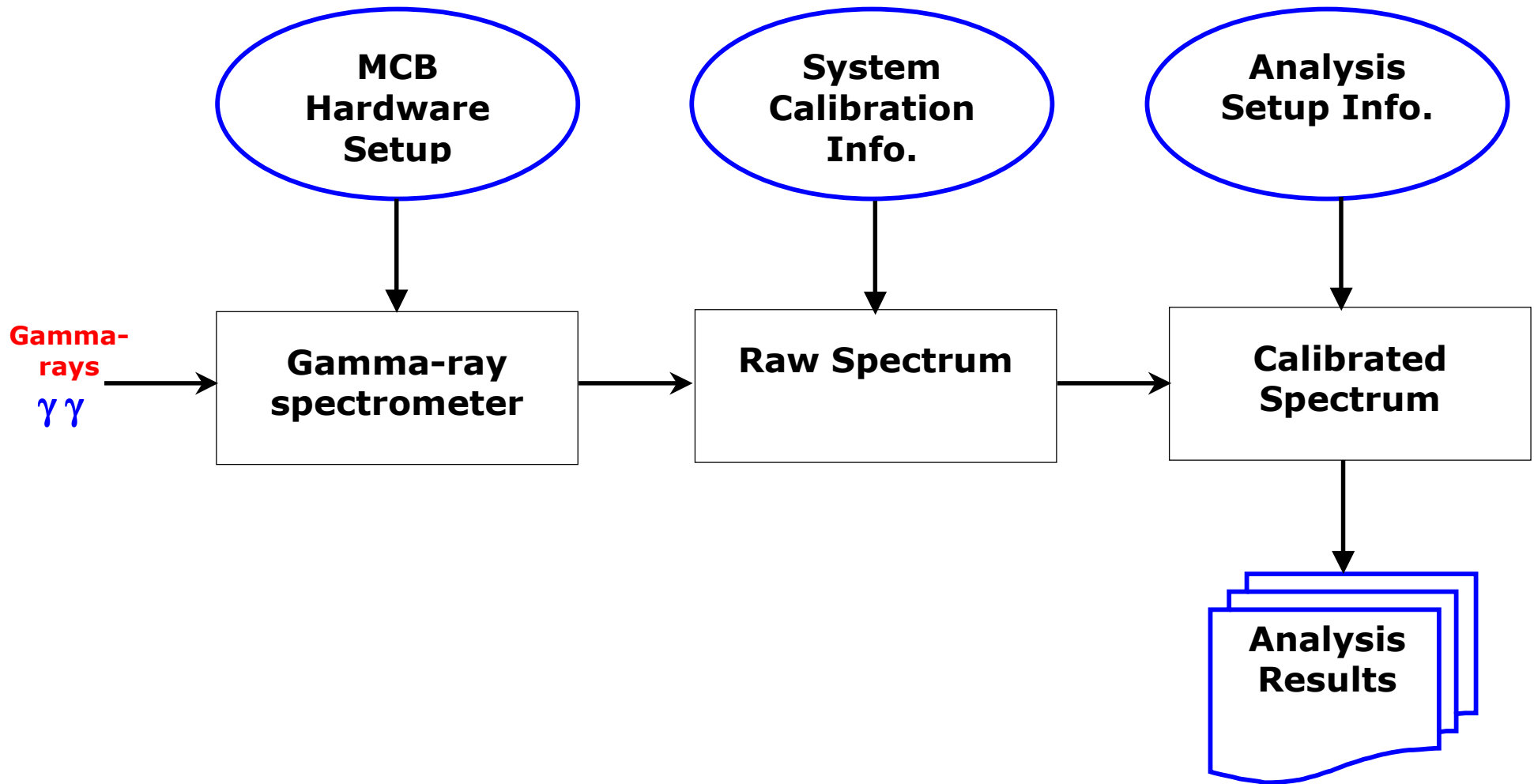


Typical connection diagram of basic gamma-ray detection system

( Both NaI(TI) and HPGe detectors are shown for explanation only )



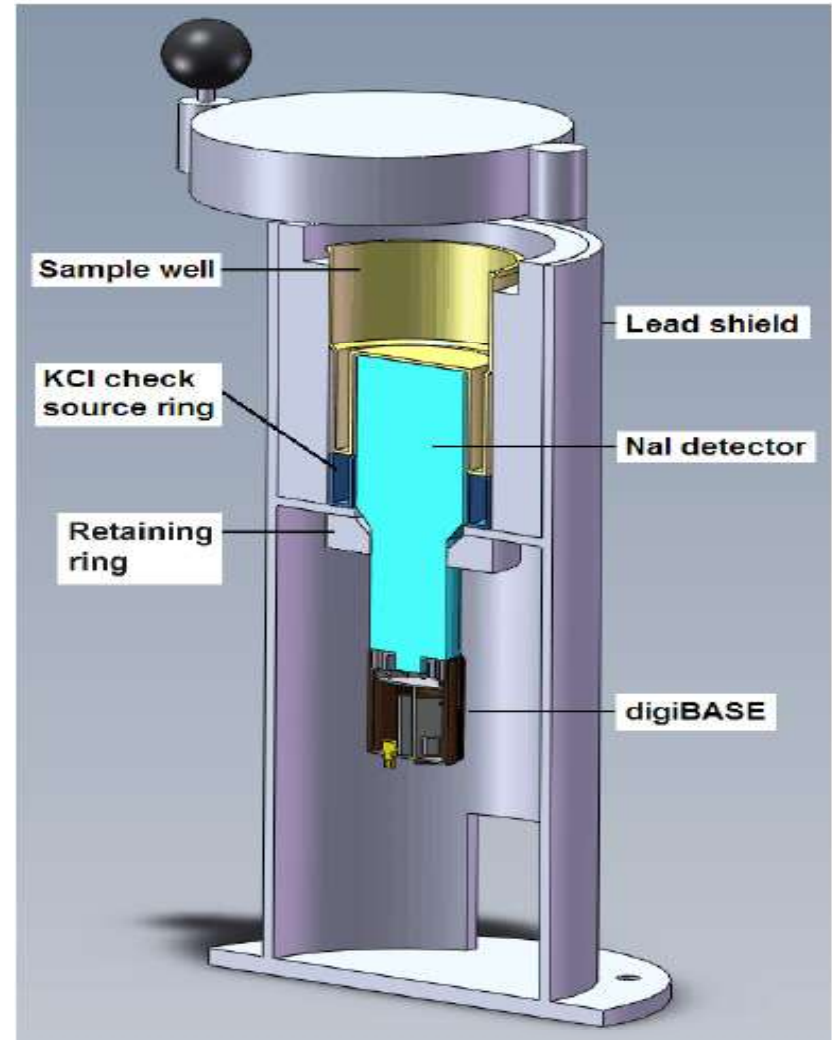
# Measurement Principles



# NaI Gamma-ray Spectroscopy System

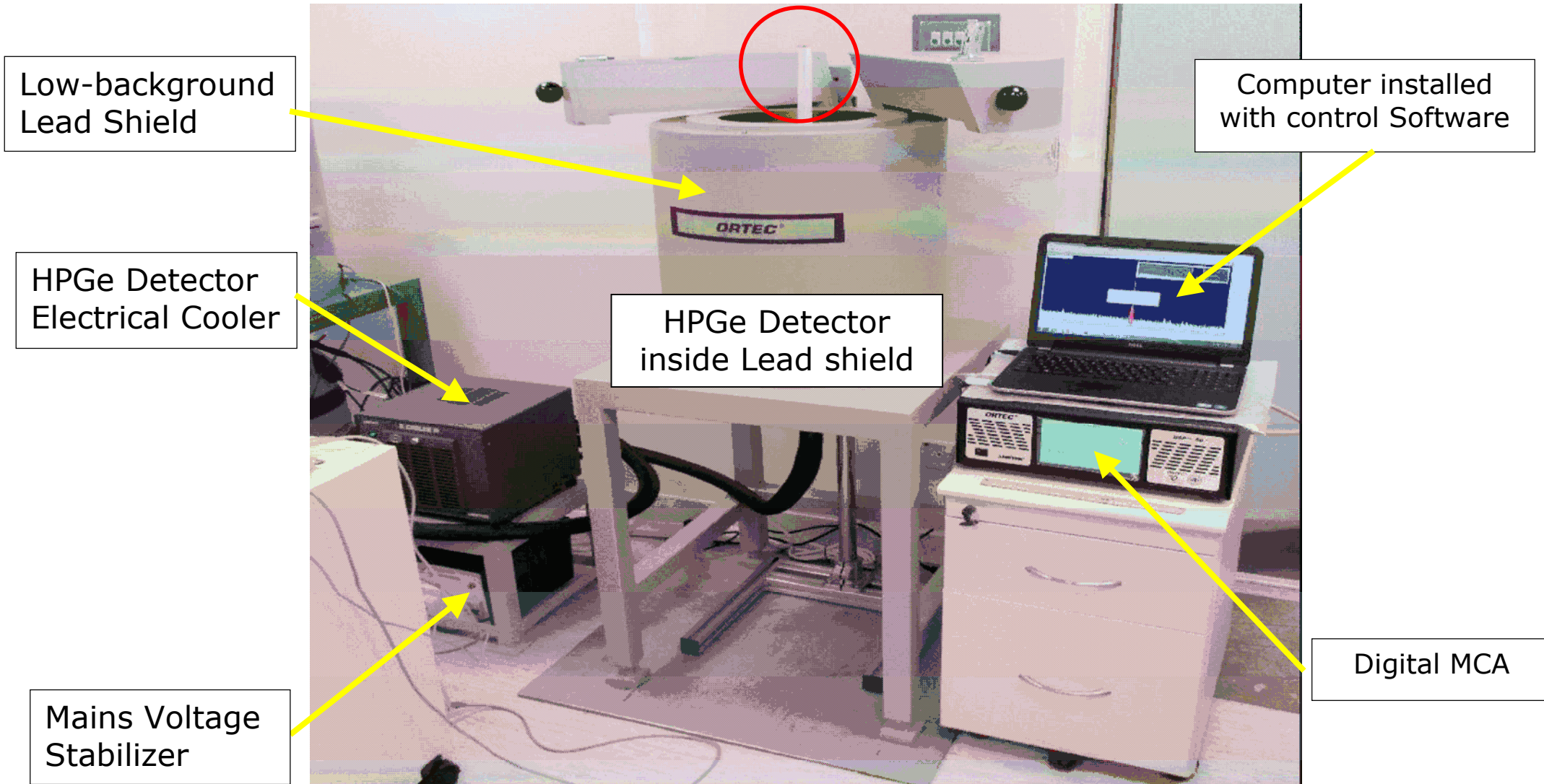


**Fig. 1a** NaI gamma-ray spectrometer



**Fig. 1b** Exploded view of Detector/ shield

# HPGe Gamma-ray Spectroscopy System



**Fig. 2** A typical HPGe Gamma-Ray Spectroscopy System using electrical cooling



## PopTop™ Detector & Detector Cooler



**PopTop™ HPGe Detector fitted on detector Cooler**

# Nuclear Physics Basics

## Interaction of gamma rays with matters :

There are three principle processes of absorption and scattering interactions of gamma photons with matter :

Photoelectric Effect (PE)	< 400keV
Compton Scattering (CS)	40 keV to 10 MeV
Pair Production (PP)	1 MeV to 10 MeV

A gamma ray may interact by one, two or all three of these processes

Other processes such as Photonucleus Reaction, Rayleigh Scattering and etc. are insignificant.

# Photoelectric Effect ( < 400 keV )

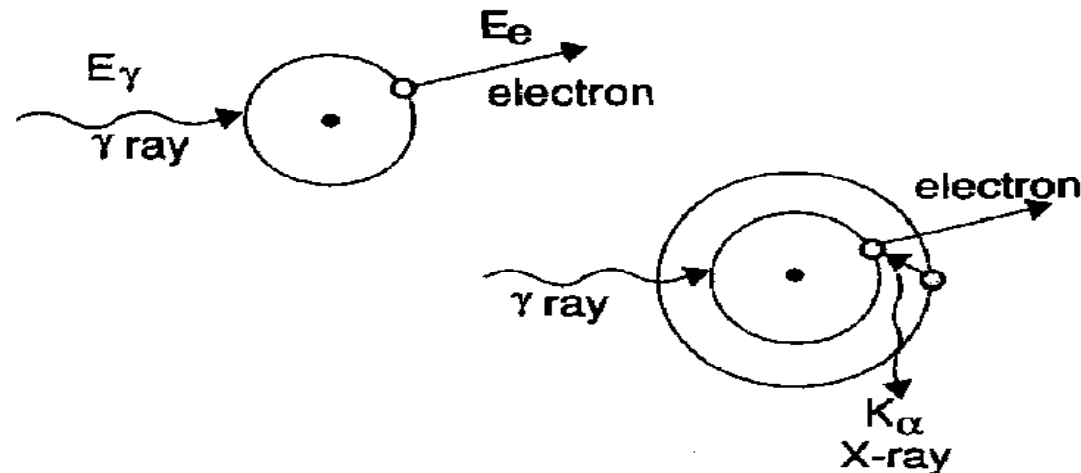
photon interacts with one bound electron; mostly in the K or L shell of an atom; an electron is ejected from its shell.

$E_e$  = Kinetic energy of ejected electron,

$E_\gamma$  = Kinetic energy of incident gamma-ray and

$E_b$  = Binding energy of electron in its shell

$$E_e = E_\gamma - E_b$$



Photoelectric Absorption Interaction and X-ray emission

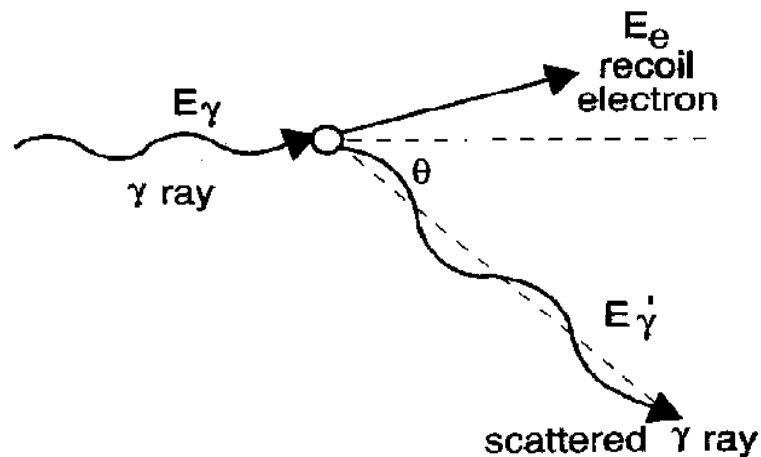
# Compton Scattering ( 40 keV ~ 10 MeV )

direct interact with an electron; mostly the outer orbitals electrons and transferring part of the gamma-ray energy

$E_e$  = Kinetic energy of recoil electron

$E_\gamma$  = Kinetic energy of incident gamma-ray

$E_{\gamma'}$  = Kinetic energy of scattered gamma-ray



$$E_e = E_\gamma - E_{\gamma'} = E_\gamma / [ ( 1 + E_\gamma ( 1 - \cos \theta ) / 511 ) ]$$

Compton Scattering Interaction

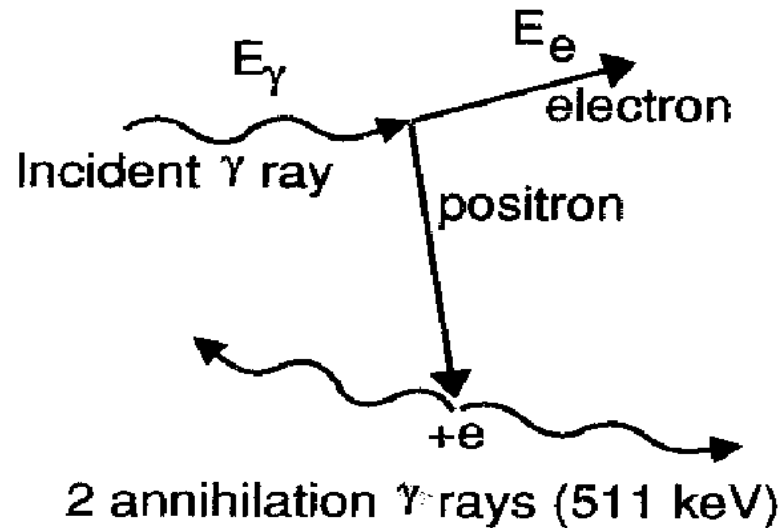


# Pair Production ( $> 1 \text{ MeV}$ )

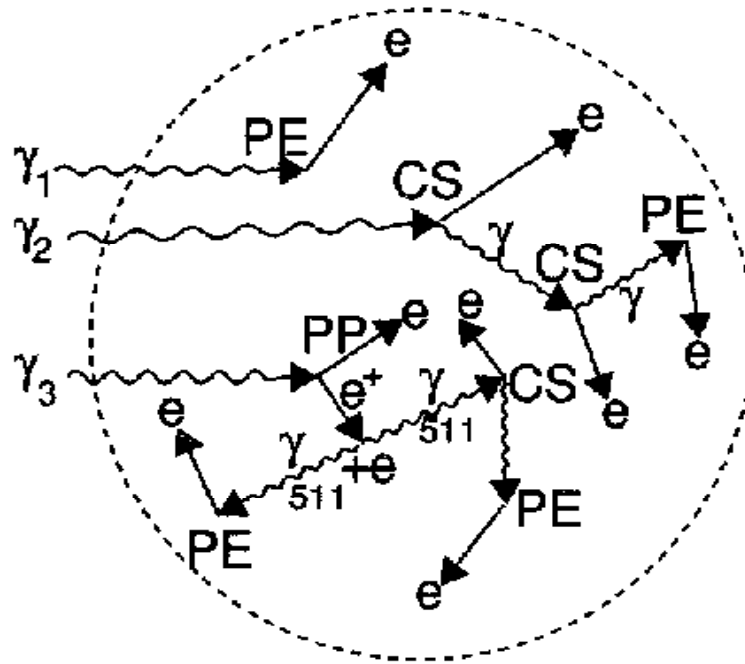
interaction of the atom as a whole

takes place within the Coulomb field of the nucleus

resulting in the conversion of gamma-ray into an electron-positron pair

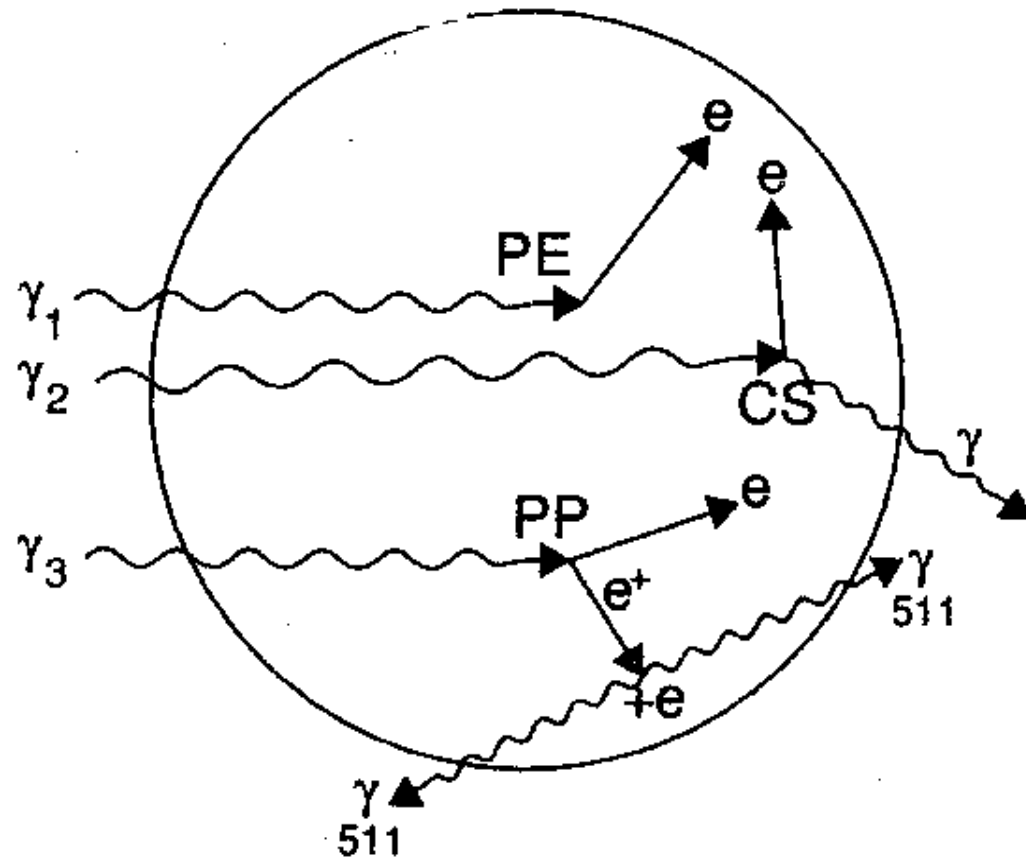


Pair Production Interaction

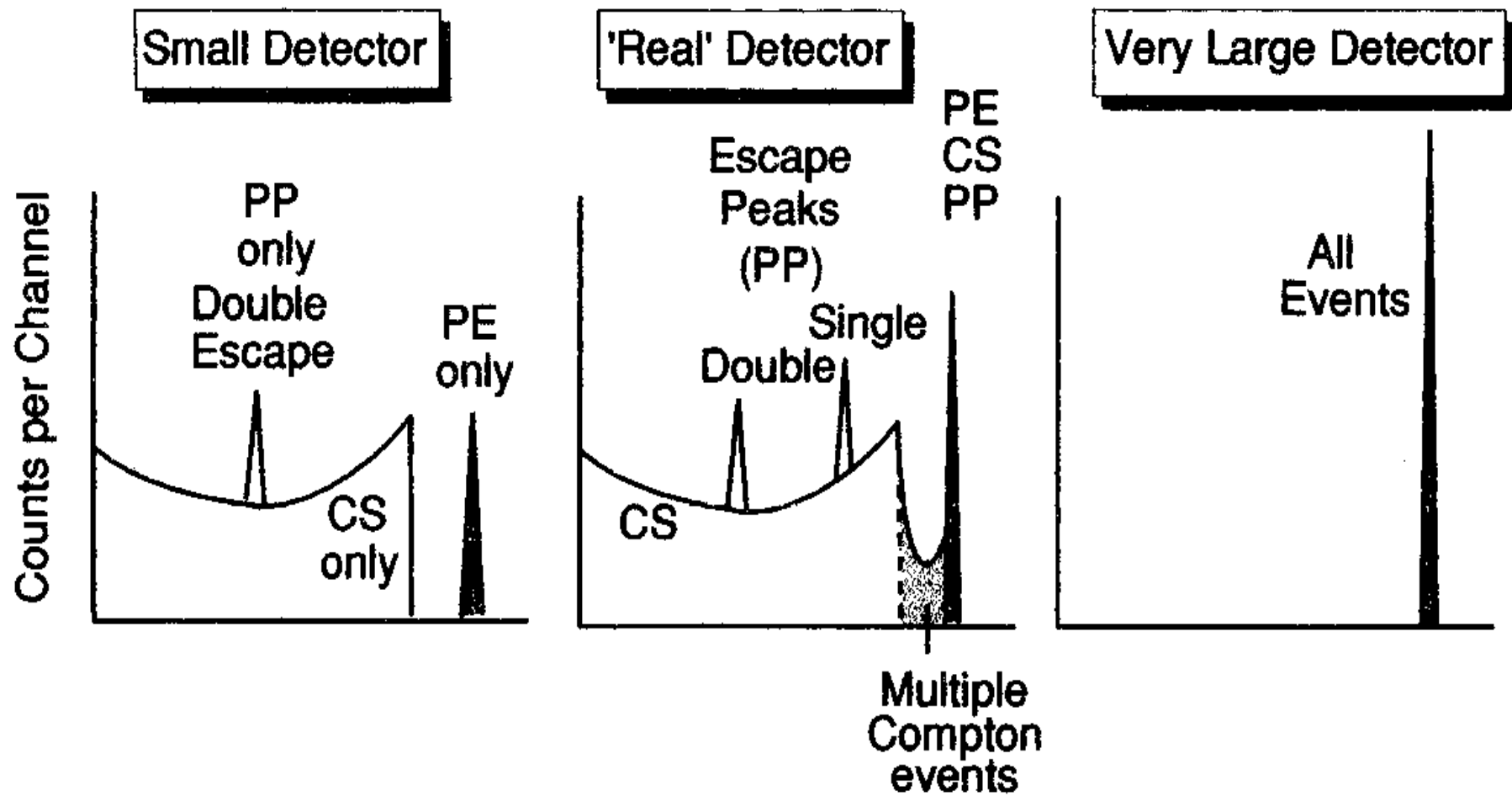


Example of interaction histories within an **infinite large** detector

- e : Electron
- e+ : Positron
- $\gamma$  : Gamma photons
- CS : Compton Scattering
- PE : Photoelectric Absorption
- PP : Pair Production



Example of interaction histories within a small detector



Detector Response (Energy Absorbed)

Spectra collected by different sizes (volumes) of detectors

# Photons interaction with detector in simple terms

convert photon energies into charges

generated charges are **linear proportion** to gamma energy

## Scintillation Detectors :

Scintillators produce 'small flashes of light' when struck by ionizing radiation (e.g. particle, gamma, neutron) and this process is called '**Scintillation**'.

Flashes of light will be further converted into charges by optical coupling to a Photo-multiplier Tube (**PMT**).

Scintillators have solids, liquids, or gases forms.

Scintillation materials are characterized by :

- Detection efficiency
- Primary decay time of produced light ( **Timing** )
- Light yield and linearity (**energy resolution**)

# Commonly used Gamma-ray Detectors :

Semiconductor Types : HPGe, CZT, CdTe

Scintillation Types : NaI(Tl), LaBr3(Ce) and LaCl3(Ce)

## Comparison of key performance parameters

Detector Type	FWHM, Resolution, 662 keV (%)	Energy Range	Photoelectron Yield	Primary decay time, $\mu$ sec	Cooling	Price Ratio to 3"x3" NaI(Tl)
<b>Scintillators</b>						
NaI(Tl)	7% or 46 keV	30keV - 3MeV	100	0.23	No	<b>1</b>
LaBr3(Ce) Lanthanum Bromide	2.8 - 4.0% or 19 - 27 keV	30keV - 3MeV	130	0.026	No	<b>40</b>
LaCl3(Ce) Lanthanum Chloride	4% or 27 keV	30keV - 3MeV	95	0.63	No	35
<b>Semi-Conductor</b>						
CZT Cadmium Zinc Telluride	2.0 ~ 3.5 or 13 to 23 keV	20keV - 1MeV	N/A	N/A	No (new type )	4 ( 1500mm <sup>3</sup> )
CdTe Cadmium Telluride	0.85keV at 122keV	20keV - 1MeV	N/A	N/A	Yes	4 ( 5 mm <sup>3</sup> )
HPGe	0.2 ( 1.3 keV )	3keV - 10MeV	N/A	N/A	Yes	<b>45</b>

## Performance comparison (1) :

- **Detection Efficiency** ( Bigger the size, higher the efficiency )

**Scintillator** : quoted by crystal volume or dimensions such as Dia. x Length ( Cyl.) or L x W x H ( Rectangular )

eg. NaI(Tl) : 1"x1", 2"x2" or 3"x3" or 4"x4"x"16"

**Semiconductor** : quoted by crystal volume or relative efficiency

eg. CZT detector : 1cm x 1cm x 1cm or 1500mm<sup>3</sup>

eg. HPGe detector : Relative Efficiency 30%

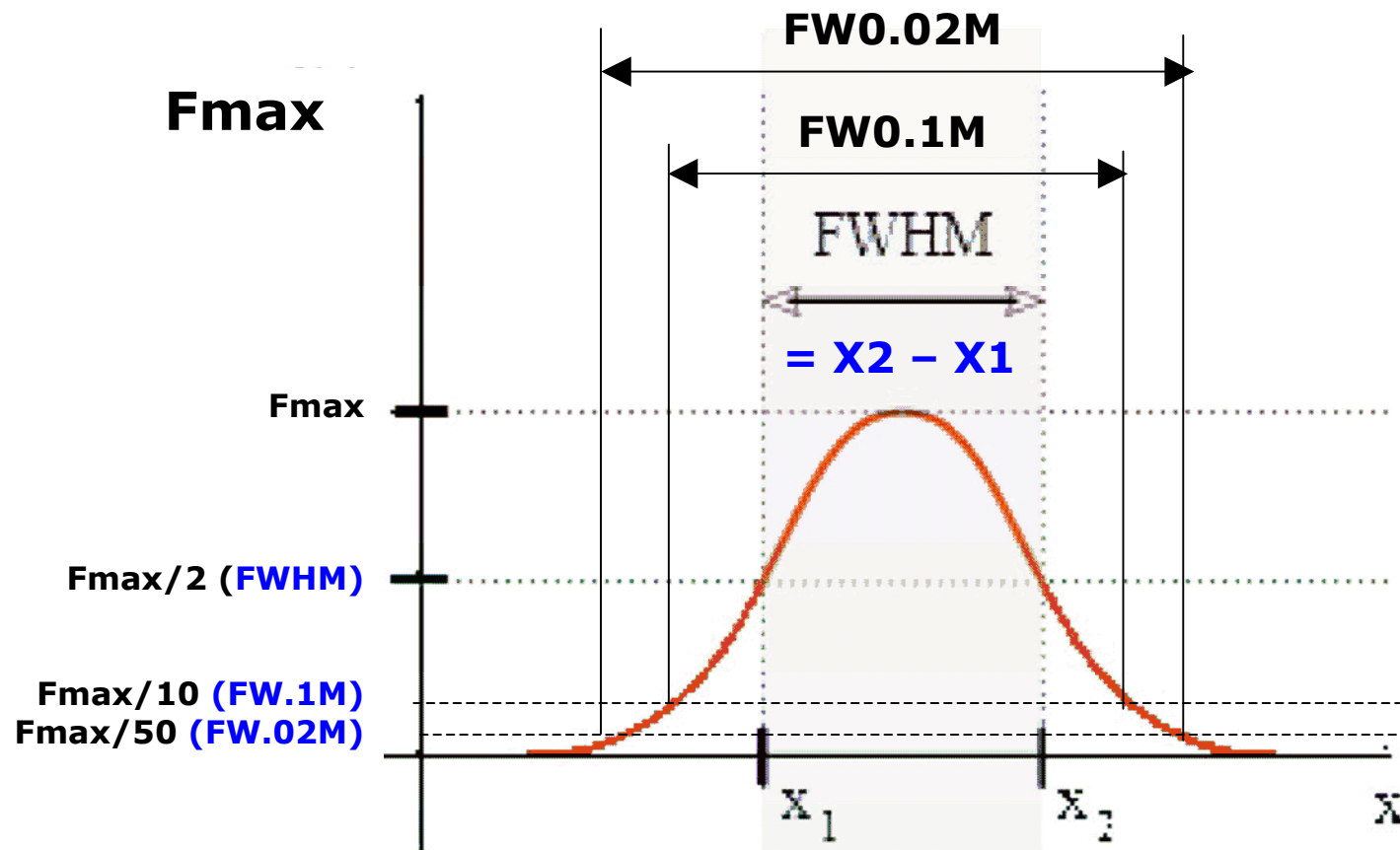
Relate to the absolute efficiency of a 3"x3" NaI detector at 1332keV of Co60 point source at 25cm above endcap; that is **0.0012**.

So, a HPGe detector with Rel. Eff. 30% means absolute efficiency of 0.00036 ( 30% x 0.0012 ) at 1332keV of Co60 point source at 25cm above endcap.



## Performance comparison (2) :

- Energy Resolution : Full Width at Half Maximum ( FWHM )  
( Smaller the FWHM the better the resolution )



## Performance comparison (3) :

- Energy Resolution and Peak Shape Ratios

**Scintillators** : quoted in keV or % of 662keV of Cs137

eg. NaI(Tl) : 7% or 46 keV at 662 keV of Cs137

**Semiconductos** : quoted in keV or % of ref. photopeak

eg. CdTe : 0.9 keV at 122 keV of Co57

eg. HPGe : 1.8 keV at 1332 keV of Co60

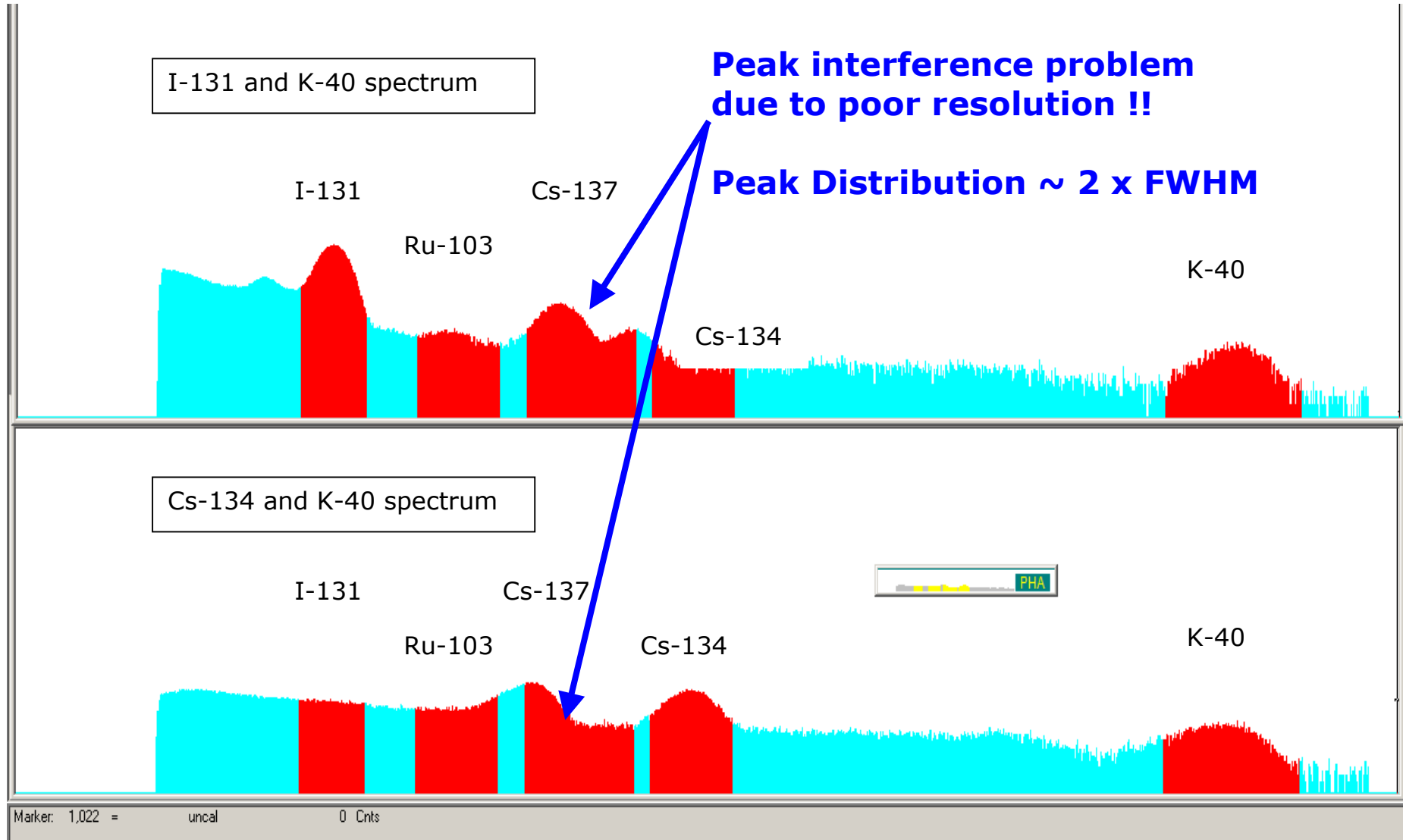
### Additional specifications for HPGe detectors :

- FW.1M : Full-Width at One Tenth Maximum
- FW.02M : Full-Width at One Fiftieth Maximum

Peak Shape Ratio: How good is the peak (Gaussian) distribution

- FW.1M/FWHM (  $\leq 2.0$  )
- FW.02M/FWHM (  $\leq 3.0$  )

# Performance comparison (4) :



## Performance comparison (5) :

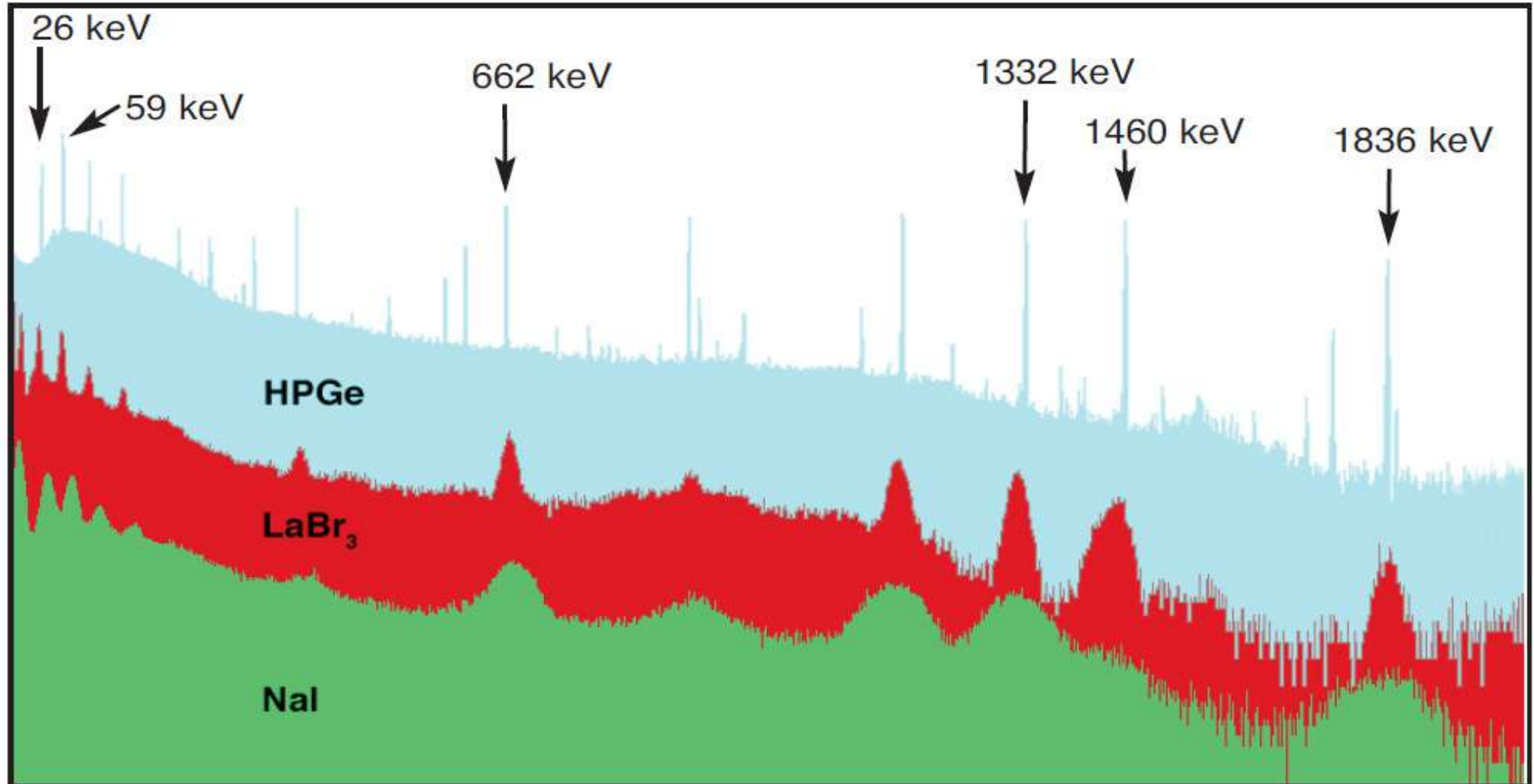


Figure 1. Comparison for LaBr<sub>3</sub>(Ce), NaI(Tl), and HPGe spectra.

\*\*Spectra are offset vertically for comparison

## Criteria for selecting a gamma spec.

1. Sampling type : Grab samples, offline or online
2. Sample geometries : beaker, vial, filter paper, disc, tank etc.
3. Radio-nuclides : e.g. I-131, Cs-137, Cs-134 etc.
4. Samples Activity :
  - Low — Below 100 cps
  - High — Above 75,000 cps input rate
  - Very High — Above 100,000 cps
5. Throughput : 5 min, 30 min., 1 hr. etc
6. Detection limits : required by local or international governing bodies

## MDA : Minimum Detectable Activity (1) :

- One measure of the quality of a spectrum is the minimum detectable activity (MDA) of the detector system.
- MDA is the lowest activity level that is practically measurable by the system with 95% confidence level for true positives and false negatives.
- **Smaller** MDA means **better** sensitivity
- MDA vary with individual sample and measurement
- MDA values depend on the characteristics of :
  1. measurement system
  2. method of measurement
  3. sample characteristics
  4. measurement conditions

## MDA : Minimum Detectable Activity (2) :

MDA proportions to  $\frac{\sqrt{B}}{\varepsilon \times \gamma \times T}$

B = Background Counts

T = Live Counting Time

$\varepsilon$  = Efficiency

$\gamma$  = branching ratio of peak

By separated out all non-detector related factors of gamma-rays per decay and counting time from MDA equation.

The resolution, background and efficiency of the detector are related to the MDA. This relationship may be simply stated as (Ref. 1):

$$\text{MDA (E)} \sim \frac{\sqrt{R(E) B(E)}}{\varepsilon(E)}$$

R(E) is the energy resolution of the detector as a function of energy;

B(E) is the background counts per keV (unit energy) as a function of energy and

$\varepsilon(E)$  is the absolute efficiency of the detector as a function of energy.

**Ref 1.** J.A.Cooper, "Factors Determining the Ultimate Sensitivity of Ge(Li) Gamma-Ray Spectrometers", Nucl Instr and Meth 82 (1970) 273-277.

MDA : Minimum Detectable Activity (3) :

FWHM at 1333keV : 65keV (NaI) & 2 keV (HPGe)

Let say, the HPGe has Rel. Eff. of 30%.

MDA improved by factor of  $\sqrt{(65/2) \times 0.3} = 3.1$

As efficiency of HPGe is 30% of a 3"x3" NaI; so it has lower background countrate than NaI of which will further improve MDA.

Also, there is **NO** peak interference on HPGe detector !



## Requirements of Calibrations :

The aim is achieving accurate and precision results of samples which are characterized by :

Gamma-ray attenuation : Energy range

Counting Geometry : point source, vial, beaker, bottle, can, petri dish, filter papers etc.

Detector Response : detector type, energy range, sizes

# System Calibration :

Calibrations ensures that gamma ray spectra are accurately interpreted in terms of :

## (1) Energy (keV) :

Energy Calibration : relationship between channels & energy

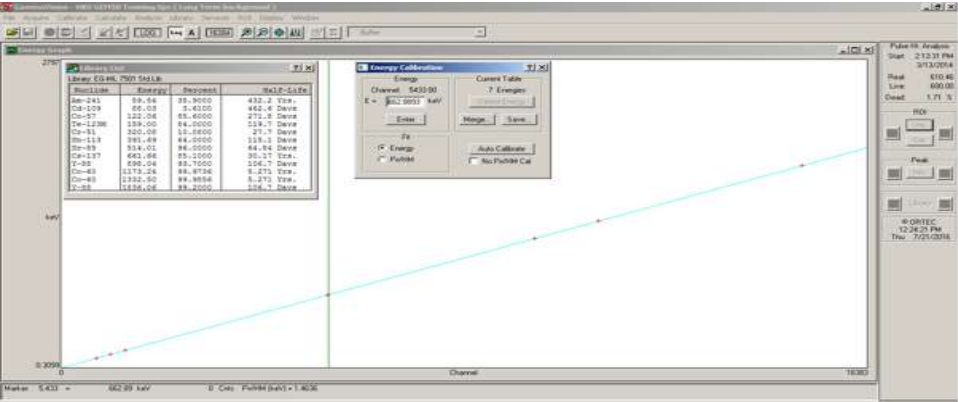
## (2) Specific activity ( Activity per unit mass or volume )

Efficiency Calibration : relationship between number of counts and disintegration rate

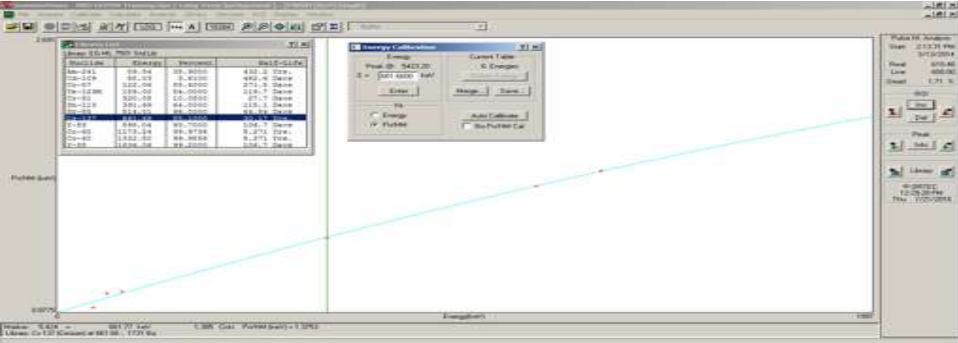
## (3) Spectral quality ( Peak Shape Adjustment for loss of primary & secondary electrons )

Peak Width Calibration : relationship of peak width vs. energy

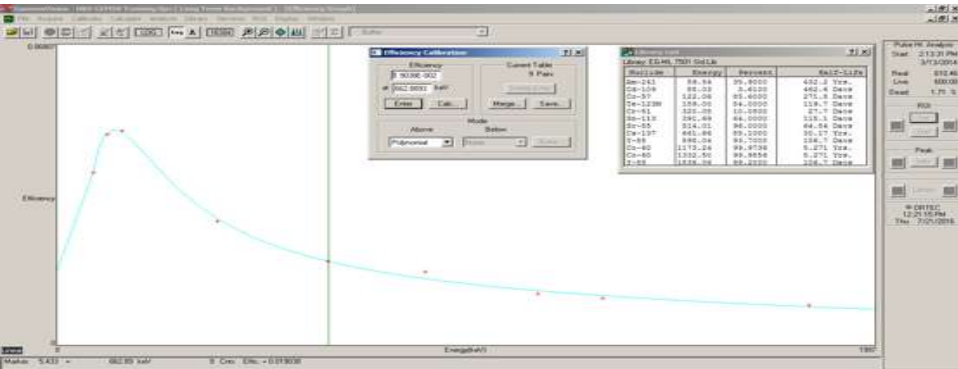
# Typical calibration curves for HPGe detectors



Energy vs Channel : Linear



FWHM vs Energy : Quadratic



Eff. vs Energy : Polynomial



## (2) Absolute : Software numerical modeling ( MCNP )

- **Monte Carlo N-Particle Transport Code (MCNP)** is a software package for simulating nuclear processes.
- It was developed by the Los Alamos National Laboratory in late 1950s
- It is distributed within the United States by the Radiation Safety Information Computational Centre in Oak Ridge, TN and internationally by the Nuclear Energy Agency in Paris.
- Computer programs simulate the process of gamma-ray detections
- The software codes generate the efficiency curve mathematically
- Data required to input to MCNP software for calculations :
  1. Detector Physical data
  2. **Detector characteristics data**
  3. Target Sample Container data
  4. Geometry Data

### (3) Semi-Empirical : a combination of Relative and Absolute

- Using a [Reference Curve](#) to derive reference curve of other geometries
- Reference curve is obtained from a standard point or beaker source.

The screenshot shows the ANGLE 3 software interface with five numbered callouts explaining the steps for creating a target efficiency curve:

- 1. Entry of Detector Physical Data**  
eg. NaI or HPGe or Well dimensions and materials etc.
- 2. Entry of Geometry Data**  
eg. Details of holder between detector and source if any
- 3. Entry of Container Data**  
eg. Beaker, disc, filter paper
- 4. Define target source**  
eg. Radius, Height and material
- 5. Create of target efficiency curve**

The software interface includes a menu bar (File, Detector, Container, Geometry, Source, Other, Calculations, Help) and a toolbar with icons for Help contents, Register ANGLE 3, Check for updates, and About ANGLE 3. The main window is divided into several panels: Detector, Container, Geometry, Source, and Other. The Detector panel shows examples of detector geometries. The Container panel shows examples of container types. The Geometry panel shows examples of holder geometries. The Source panel shows input fields for source height, source radius, and source material. The Other panel shows input fields for energies, reference efficiency curve, calculation precision, and all dimensions are in.

## Performance comparison among different calibration methods

Method	Pros	Cons
Relative	Highly Accurate	Less Flexible and costly
Absolute	Accurate & Flexible	<ul style="list-style-type: none"><li>• Required extensive knowledge</li><li>• Difficult to define parameters</li><li>• Impossible to model detector properties changed over time</li></ul>
Semi-Empirical	Accurate & Flexible Typ. Accuracy of 3~5%	

# Formats of HPGe Gamma-spec. :

## Nuclear Instrumentation Modules (NIM) format (1)

**It was the only available system format during the 70 ~ 80's**

**Advantages :**

- Highly flexible for configuration
- Most NIMs are multi-functional

**Disadvantages :**

- Difficult to use
- Need in-depth knowledge for using each NIM
- Need a lot of cables, adapters and accessories



**Front and Back panels  
Spectroscopy Amplifier**

**Front and Back panels  
High Voltage Bias Supply**



## Nuclear Instrumentation Modules (NIM) format (2)

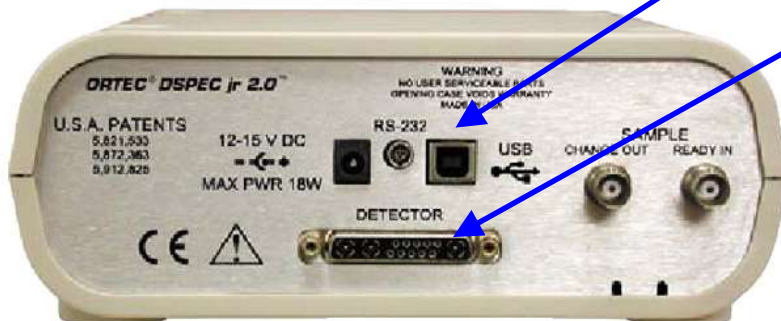


HPGe detector based Gamma-ray System implemented by NIMs

# Bench-Top Digital Signal Processored Spectrometer can use with NaI, HPGe, CZT, LaBr3, LaCl3 detector



**DSPEC PRO Front Panel**



**DSPEC PRO Rear Panel**

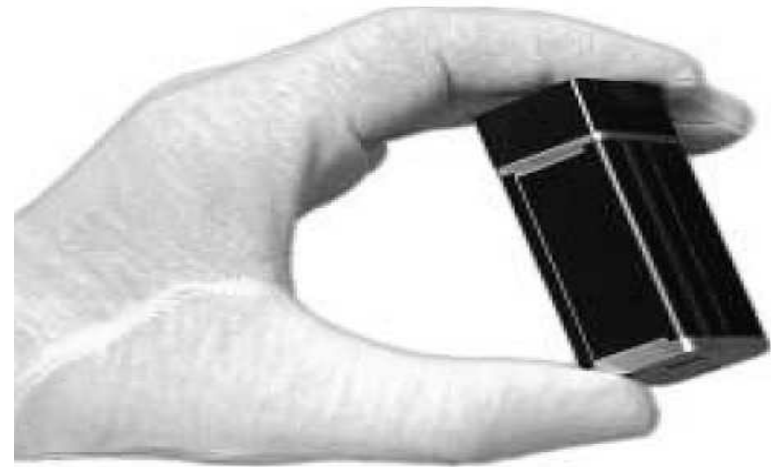
USB Connection

Detector Interface

## Integrated Spectrometer ( MCA with Detector ) :



**Spectrometer with 1"x1" NaI**



**Spectrometer with 1500mm<sup>3</sup> CZT**

**Complete Gamma Spectroscopy System Consists of :**

- **Detector**
- **Cooling System**
- **Electronics**





# Handheld RadioIsotope IDentifier ( RIID ) : Complete gamma-ray spectrometer



**Handheld NaI Spectrometer**



**Handheld HPGe Spectrometer**

# Digital Spectrometer and MCAs for Scintillation Type Detectors :

NaI (TI) / LaBr<sub>3</sub>:Ce / LaCl<sub>3</sub>:Ce



## Gamma-Ray Spectroscopy Systems in HKG :

- (1) Environmental Counting Systems : HKO
- (2) Online Water Contamination Monitoring System : WSD
- (3) Contamination Monitoring Systems ( CMS ) : FEHD,AFCD,WSD
- (4) Automatic Gamma Spectrometry System (AGSS) : HKO
- (5) Livestock Contamination Monitoring Systems : FEHD
- (6) Automatic Sampling Counting System : Govt. Lab.
- (7) Absolute Activity System ( Primary Standard ) : Govt. Lab

# (1) Environmental Counting Systems :

**Customer** : HK Observatory

**System** : HPGe Gamma-ray Spectrometers ( 5 Systems )

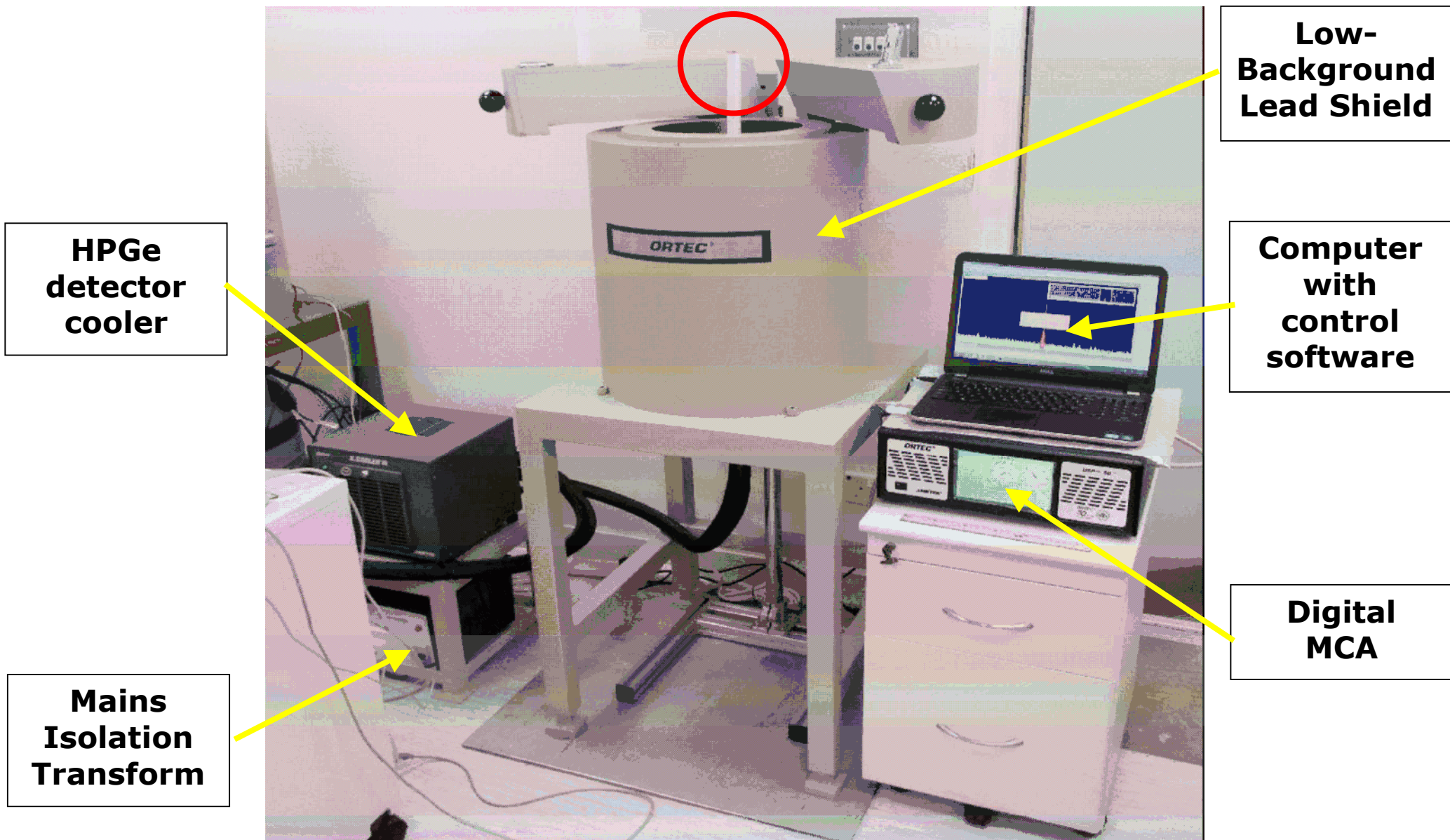
**Location** : King's Park Meteorological Station

**Applications** : Routine measurements of environmental sample of air, soils, Water and foodstuffs

**Features** :

- large variety of sample types and quantities
- using relative, empirical & semi-empirical calibration methods
- HPGe detectors with LN2 and electrical cooling
- using NIM-based and digital integrated spectrometers





**HPGe  
detector  
cooler**

**Low-  
Background  
Lead Shield**

**Computer  
with  
control  
software**

**Mains  
Isolation  
Transform**

**Digital  
MCA**

**A typical HPGe gamma-ray spectrometer using electrical cooling**



## (2) Online Water Contamination Monitoring System

**Customer** : Water Supplies Department

**System** : Online Water Contamination Monitoring Systems

**Location** : Muk Wu Pumping Station ( near Man Kam To )

**Applications** : To continuously monitor the radiation levels of water imported from Guangdong

**Features** :

- Online monitoring system
- Digital Spectrometer and HPGe Detector with Electrical Cooler
- Unmanned system with remote control support
- Full spectral analysis
- Ruggedized and User-friendly
- All monitoring results are transmitted to the HKO & WSD
- Sampling Rate of 22 Litre per minute
- MDC of < 0.25 Bq/L per hour for Cs137

For details refer website : [http://www.hko.gov.hk/education/dbcp/new\\_Emas/eng/r11.htm#](http://www.hko.gov.hk/education/dbcp/new_Emas/eng/r11.htm#)



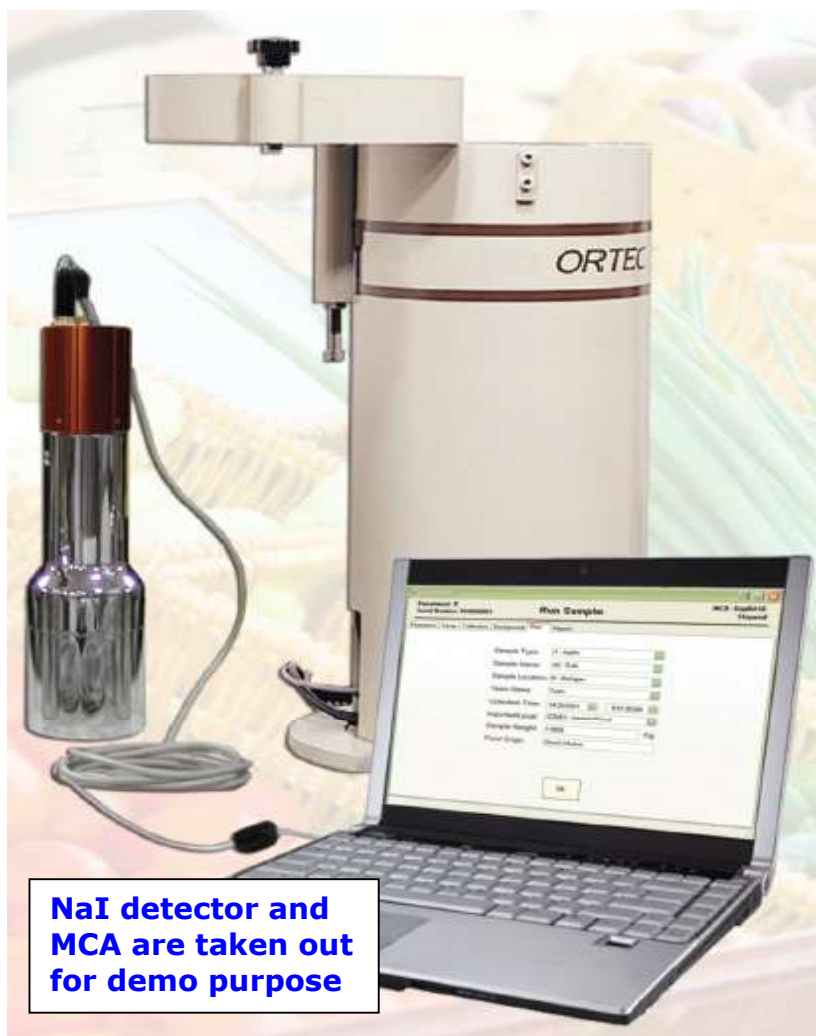
**OWCMS Lead Shield**



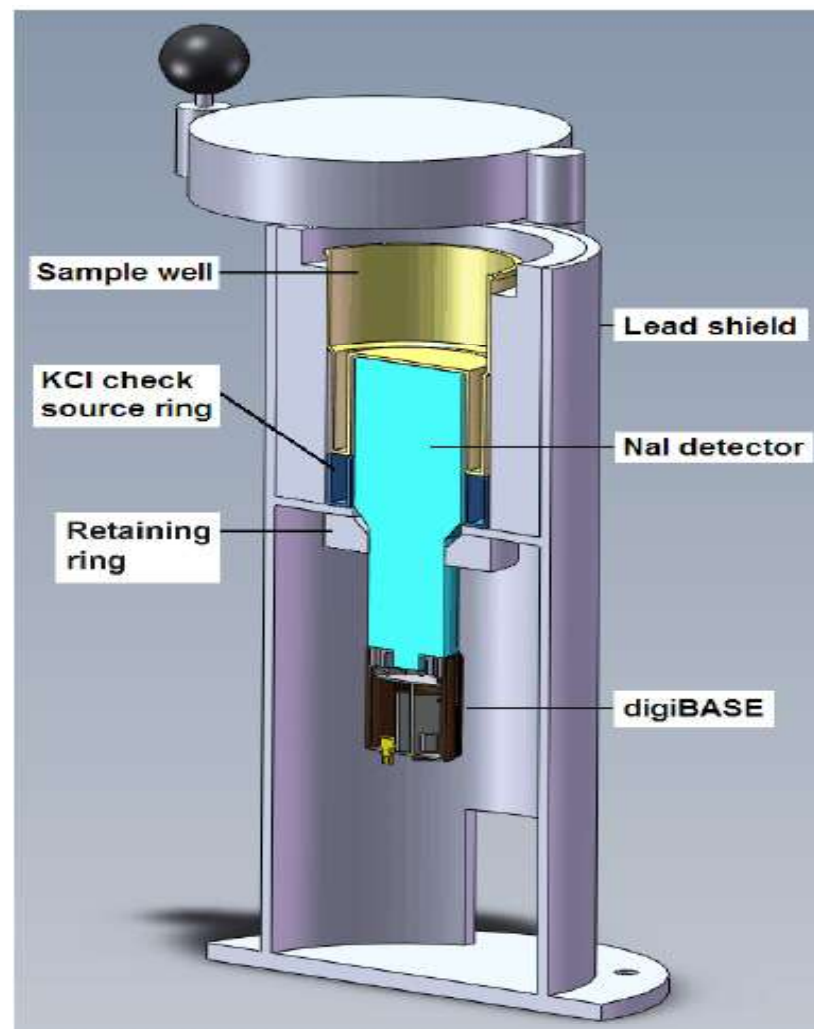
**HPGe detector inside the Lead shield**

## (3) Contamination Monitoring Systems ( CMS )

- Customer** : Govt. dept. of AFCD, FEHD, WSD, Govt. Lab. HK Observatory etc.
- System** : Contamination Monitoring Systems ( 40+ systems )
- Locations** : at various food control offices, wholesale markets and laboratories
- Application** : Screening imported foodstuffs, local produce & water resources for radiation levels per the World Health Organization guidelines
- Features** :
- Digital integrated gamma-ray spectrometer
  - 3" x 3" NaI detector
  - Mobile Cart option for easy deployment
  - Full spectral analysis
  - Measure I-131, Ru-103, Cs-137 and Cs-134
  - MDC < 15 Bq/kg for Cs-137 in 10 minute
  - Adopted USA FDA approved "Interference ROI matrix" method



**Contamination Monitoring System**



**Exploded view of Detector/ shield**

## (4) Automatic Gamma Spectrometry System (AGSS)

**Customer** : Hong Kong Observatory

**System** : Online Automatic Gamma-ray Spectrometry System

**Location** : Mirs Bay, ( East ) Ping Chau

**Detector** : High-Purity Germanium Detector with Electrical Cooler

**Application** : To continuously monitor the environmental radiation at vicinity area including Daya Bay, Guangdong

**Features** :

- Online monitoring system
- Unmanned system with remote control support
- Gross alpha & beta, I-131 gaseous & gamma spectral analysis
- All monitoring results are transmitted to the HKO Headquarters
- Automatic triggering alarm at HKO for any pre-alarm exceed
- Air Sampling Rate of 25 m<sup>3</sup>/hr.
- MDC < 1.2 Bq/m<sup>3</sup> per hour for I-131

For details refer website : [http://www.hko.gov.hk/education/dbcp/new\\_Emas/eng/r7.htm](http://www.hko.gov.hk/education/dbcp/new_Emas/eng/r7.htm)



**AGSS Location map**



**AGSS Enclosure**



**AGSS System**  
Copyrights © 2016 Ficom Systems Ltd.

## (5) Livestock Contamination Monitoring Systems

**Customer** : Food and Environmental Hygiene Department

**System** : Livestock Contamination Monitoring Systems

**Locations** : Man Kam To Boundary Control Point, Lok Ma Chau Boundary Control Point and Sheung Shui Slaughter House

**Application** : Screening radiation levels of imported livestock of cattle, pig and goat

**Features** :

- Digital Gamma-ray Spectrometers
- Dual large-sized 4"x4"x16" NaI detectors
- Mobile Cart format for easy manoeuvre
- Full spectral analysis
- Custom-made software
- Measurement Configurations of Truck load and Single head
- MDC < 30 Bq/kg for Cs-137 in 1 minute
- WIFI / LAN interface remote control option

For details refer website : [http://www.hko.gov.hk/education/dbcp/new\\_Emas/eng/r13.htm#](http://www.hko.gov.hk/education/dbcp/new_Emas/eng/r13.htm#)





Detector, heaters, Lead Assembly & MCAs inside mobile cart



Screening radiation level of cattle



Mobile Cart at Measurement



## (6) Automatic Sampling Counting System

**Customer** : Government Laboratory

**System** : Automatic Samples Counting System

**Location** : Public Works Central Laboratory Building, Kowloon Bay

**Application** : Screening radiation levels of imported health care products

**Features** :

- Digital Gamma-ray Spectrometer
- HPGe detector with electrical cooling
- Unmanned system
- Manual and Automatic Operation modes
- Maximum of 16 samples per run
- Configurable Sample beaker sizes
- MDC < 30 Bq/kg for Cs-137 in 1 minute

# Government Laboratory : HPGe Gamma-Spec with auto. sample changer



**Automatic Counting System**



**Detector inside Lead shield**

## (7) Absolute Activity System ( Primary Standard ) :

**Customer** : Government Laboratory

**System** : Absolute Activity System

**Location** : Pokfulam, Hong Kong

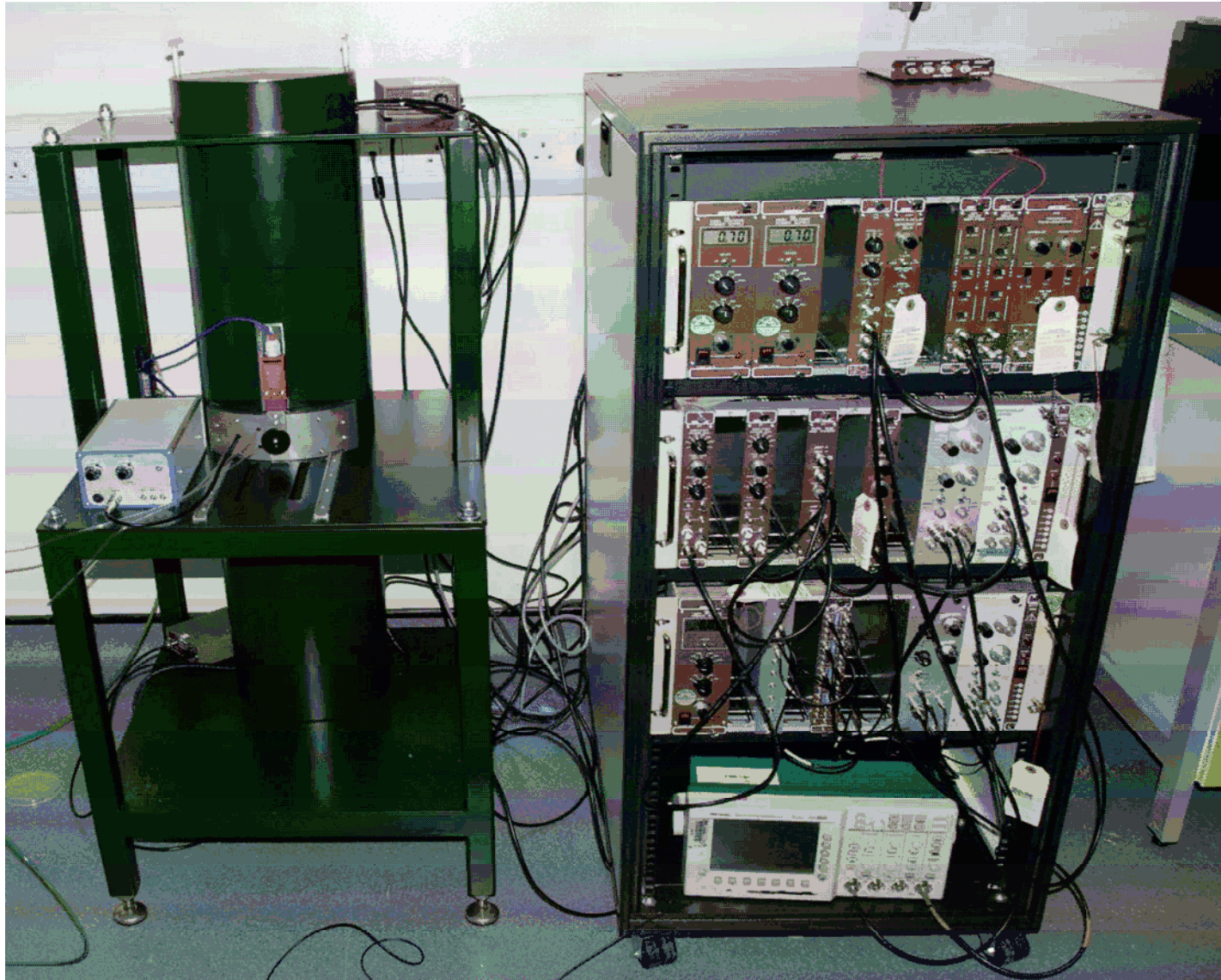
**Detector** : Dual 3"x3" NaI detectors & an ultra low-background beta detector

**Application** : Standardise radio-nuclides ( primary standard )  
( Collaboration with National Physical Laboratory, England, UK )

**Features** :

- Hybrid system of NIM-based and digital spectrometer
- Multi-detector coincidence counting system ( beta & gamma )
- Flexible to configure for different radio-nuclides measurement
- Specialized software for data analysis





**Absolute Activity System**